



Coupling by Straub

For Concrete Pipe and Manhole Applications

Pipe and manhole joints under high pressures have traditionally been costly and challenging to seal...until now.

Municipalities often require design pressures of up to 50 psi / 345 kpa for sewer lines running near drinking water pipelines, for lines under pressure, and even on manhole connections in locations with high water tables. These joints must surpass the specification requirements of CSA A257 or meet ASTM C361. Hamilton Kent, partnering with Straub, has changed the connection landscape with a high pressure coupling for concrete pipe and manholes.

Designed for manhole connections where injection grouting is typical or for high pressure pipe-to-pipe connections, the HK Coupling by Straub for concrete applications is a cost-effective solution that installs with relative ease. These couplings can be installed on any variation of straight wall concrete pipe and manhole – including bell and spigot, and tongue and groove joint designs.

Features and Benefits:

- ***Two or three-bolt couplings*** provide a lightweight, low-profile design that allows for fast and easy installation around the pipe – for all sizes of straight wall pipe or manhole.
- ***The rubber gasket of the coupling*** compensates for minor pipe imperfections such as misalignment, angular deflection, gap, ovality and rough concrete surface.
- ***Corrosion resistant*** 316L stainless steel casing and lock parts.
- ***Compensates for axial movement*** caused by ground settlement and thermal expansion/contraction.
- ***Bell and spigots do not need to be specially designed***, allowing the pipe producer to save manufacturing costs.
- ***Eliminate the need for steel end rings***, reducing manufacturing costs.



***Making Infrastructure Watertight Today
for a **Greener**, Sustainable Tomorrow***

Materials and Identification

Components / Materials	W1	W2	W5
Casing	S355MC, hot-dip galvanised	AISI 316 L or similar	AISI 316 L or similar
Bolts	AISI 4135	AISI 4135	A4 - 80
Bars	AISI 12L14, galvanised	AISI 12L14, galvanised	AISI 316 L or similar
Strip insert (option)	AISI 316 L or similar / HDPE	AISI 316 L or similar / HDPE	AISI 316 L or similar / HDPE

Sealing sleeve EPDM	Temp.: -20°C up to +100°C (-4°F to +212°F) Medium: all qualities of water, waste water, air, solids and chemical products
Sealing sleeve NBR	Temp.: -20°C up to +80°C (-4°F to +176°F) Medium: water, gas, oil, fuel and other hydrocarbons
Sealing sleeve FPM /FKM (on request)	Temp.: -20°C up to +180°C (-4°F to +356°F) Medium: ozone, oxygen, acids, gas, oil and fuel (only with strip insert)

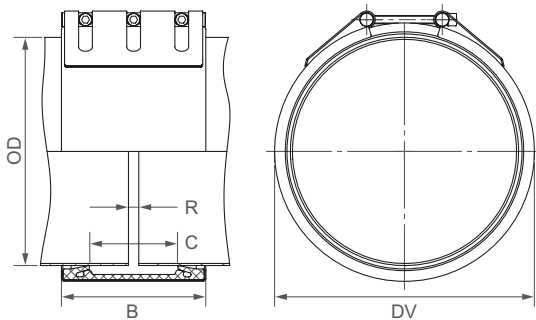

Versions W1, W2 and W5 vary by material and size requirements. Please contact your HK representative for product selection.

B = 210-218 mm (8.27-8.58")
DV = OD + 38 mm (+ 1.50")
C = 127 mm (5.00")

R with strip insert = 60 mm (2.36")
R without strip insert = 15 mm (0.59")

Pressure Rating

Couplings by Straub are designed to provide watertight connections up to 50 psi/345 kpa.

Linear Misalignment

1-2% of outer diameter (max 0.25"/6 mm) is admissible. Larger misalignment must be rectified into angular deflection. (Cardan principle)

Installation Preparation

We recommend in-plant testing prior to installation in the field to ensure the pipe produced and the coupling recommended meet the design requirements.

- Clean the concrete surface of impurities where the coupling will seal. There should be no dirt under sealing surface.
- Mark half the coupling width on both pipe ends.
- Loosen but do not dismantle the pipe coupling.
- Do not drop the pipe coupling (risk of deformation).

Installation Steps

1. Apply lubrication to the pipe ends. Note that the inside of the coupling and outside of the gasket should come lubricated. Large couplings may ship disassembled, so apply silicone based lubricant to the gasket and coupling housing in the field.
2. Push the coupling completely over one pipe end.
3. Fully home the joint together in straight alignment, and orient the coupling housing evenly between the marks made during the preparation stage.
4. Adjust pipe coupling, then tighten bolts lightly and alternately with a ratchet wrench or power wrench. DO NOT use the power wrench for stainless steel screws.
5. Tighten the locking bolts with a torque wrench to the final prescribed torque rate engraved on the coupling's outer surface. Repeat the tightening sequence until a quarter turn or less is needed to reach the required torque.
6. After 10 rotations of the torque wrench, equalize the gasket by tapping around the entire circumference of the coupling housing with a rubber mallet. Do this again after the first click of the torque wrench.



TEL: (800) 268 8479

FAX: (888) 674 6960

WEB: www.hamiltonkent.com

E-MAIL: information@hamiltonkent.com